

# Installing Solid Fuel Stoves

A guide to installing domestic stoves in accordance with Approved Document J - Combustion Appliances and Fuel Storage Systems 2010 Edition Building Regulations 2010.



The guidance contained in this document has been prepared by the Hertfordshire Technical Forum for Building Control.

The installation of wood burning and multi fuel stoves is work that is controlled under the Building Regulations as is the re lining or installation of flues and chimneys associated with such heat producing appliances. This means that it is usually necessary for a house owner to submit an application to Building Control before starting such work. The following pages contain a brief description of the building regulations that apply. You can find more detailed information in Approved Document J of the Building Regulations 2010 and you can download this document from the planning portal at [www.planningportal.gov.uk](http://www.planningportal.gov.uk) . The Building Control section at your local council will also be able to give you any further advice you may need. **Although qualifications are not mandatory, any person fitting a solid fuel stove must be competent to do so i.e. familiar with the correct procedures and associated regulatory requirements.**

# Hertfordshire Technical Forum for Building Control Guide to Installing Solid Fuel Burning Stoves

## INDEX

Page	Subject
2	Competent persons schemes
3	Applications to Building Control Connecting to existing chimneys Re lining chimneys
4	Stove flue sizes New masonry chimneys
5	Single wall flue pipes Factory made metal chimneys
6	Outlets from flues and chimneys Hearths for stoves
8	Ventilation for stoves Positioning ventilation for a stove
9	Notice plates
10	Carbon Monoxide Alarms Commissioning check list Planning permission Other information

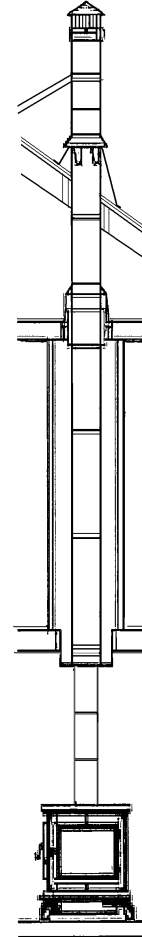

### Note on Thatched Roofs

This guide does not cover installations in properties with thatched roofs or other roofs with easily ignitable finishes. You can find relevant information in the HETAS Information paper 1/007 *Chimneys in Thatched Properties* or by calling your local Building Control office.

### Competent Persons Schemes

Some installing companies are registered with a government approved 'competent persons scheme' that enables them to self certify their own work as compliant with the relevant regulations. If you choose to have your stove installed by such a company then you will not need to submit an application to Building Control. The most common scheme provider for such work is HETAS ( [www.hetas.co.uk](http://www.hetas.co.uk) ). Make sure that the installer is listed as registered and leaves you with a certificate of compliance at the end of the job.



## **Applications to Building Control**

For other installations it is necessary for an owner to make an application for Building Regulations permission. This involves filling in an application form, sending it with the necessary fee and details of the installation to your district or borough council. A 'Full Plans' application needs to include full details and specifications of the stove and associated information to demonstrate compliance. You may alternatively submit a 'Building Notice' application. With the latter it is not essential that you include details and specifications although Building Control may request these when the work starts. A disadvantage of the latter method is that the installer will not have approved specifications to work to. This can cause problems when Building Control later inspects the work. Relevant forms and fee information are available from your local authority offices.

When you start work following approval of your application you are legally obliged to notify the council. A Building Control Surveyor will inspect the works to ensure compliance and on satisfactory completion you will receive a certificate confirming that they are satisfied that the work complies. This may be an important document should you later decide to sell your property.

## **Connecting to Existing Chimneys**

An existing chimney must be given a visual inspection to check that it is in good order, clear of obstructions such as dislodged masonry or bird's nests and is of a suitable size and type for the appliance you plan to install (see below). It will probably be necessary to sweep the flue which should always be done anyway before fitting a stove or lining a chimney. Old chimneys are often very inefficient and particularly if unlined, can leak products of combustion and tars through the chimney walls. It is quite common to find that old chimneys are in a poor condition due to the flue surface and mortar joints being eaten away by corrosive condensates and soot deposits. It was only in 1965 that Building Regulations required that all new chimneys had to be built with suitable flue liners of the correct flue size to protect the chimney structure.

It is therefore very wise to have any old chimney you are using checked for its condition and particularly if you are planning to re-open an old chimney after many years of not being used. A smoke test should then be carried out to establish whether there is any major fault that can cause products of combustion to leak through the chimney walls. The correct procedure for a smoke test is described in The Herts Technical Forum's Guidance Note 8 Commissioning of Heat Producing appliances. The general condition of the chimney in terms of structural stability should also be checked, as well as making sure it is wind and water tight.

## **Re Lining Chimneys**

Carrying out the above checks should identify any repair work that is needed and it is often necessary to have the chimney fitted with a new liner, which should improve both performance and safety. There are many factory made relining systems available made from clay, ceramics or refractory concrete consisting of pumice or kiln burnt aggregate bonded with high alumina cement. These liners are simply lowered down the chimney on guide ropes with locating bands at the joints. The gap between the liners and chimney is then backfilled with an insulating lightweight concrete. Whilst this type of lining offers a long life, the existing flue opening has to be large enough for the correct sized liners to be installed and it is necessary to open up the chimney to install bends causing disruption and the need to make good and redecorate.

Re lining with steel is an alternative method with advantages and disadvantages. Not to be confused with single skin liners for gas, multifuel flexible liners are double skinned and made from an extremely high quality stainless steel, usually 904L or 316Ti (Titanium) grade. They are smooth on the inside, corrugated on the outside and must be installed the correct way up.. They are simply lowered down or pulled up the chimney and can go around most bends their slim profile enabling quick installation into chimneys where other systems might not easily fit. Their life can be reduced if abnormally high corrosive soot or condensate deposits are created and allowed to accumulate in the flue or have not been thoroughly removed from the walls of the existing chimney flue. The backfilling of the steel liner with insulation is not specifically mentioned in Approved Document J but is a good idea for efficient operation and a good 'chimney draw'.

Other re lining systems available include the use of pumped refractory concrete, spray on linings and ceramic coatings. Always check with HETAS or Building Control that such systems are regulations compliant.

### Stove flue sizes

The flue size (diameter or cross sectional area) must not be smaller than the size of the stove outlet.

Building Regulations require that the minimum flue size for stoves is as follows:

up to 20kW burning smokeless fuel - Minimum 125mm diameter.

up to 30kW burning any fuel - Minimum 150mm diameter.

In the long term it is difficult to control the type of fuel that may be burned so we would strongly recommend that 150mm is the minimum size used.

If rectangular or square flues are used then they should have an equivalent cross sectional area and a minimum dimension of 100mm for straight flues and 125mm for flues with bends.

### New masonry chimneys

These can be divided into two categories:

a) Conventional brick or masonry construction with either clay/ceramic liners certified to BS EN 1457 or refractory concrete flue liners certified to BS EN 1857. To form a chimney, the liners have to be surrounded with at least 100mm thick brick, block or stonework with the gap in between filled with insulating concrete ie leca, vermiculite, or perlite (unless manufacturers guidelines say otherwise).

b) Prefabricated chimney block systems certified to BS EN 1858 comprise an inner liner of concrete or clay / ceramic as specified above and an outer block of insulating concrete. Chimney blocks are designed to be used as a building unit and can normally accommodate a range of appliances.

New masonry chimneys should be constructed with flue liners and components that are suitable for the stove being fitted. The steel products used for re lining are not acceptable in new chimneys. Manufacturers' installation instructions must be closely followed.

New chimneys need to be constructed off suitable foundations They should incorporate a damp proof course just above ground level and appropriate weathering where passing through the roof. Further information on the latter can be found on the Lead Sheet Association's website at [www.leadsheetassociation.org.uk](http://www.leadsheetassociation.org.uk) . It is essential that adequate clearance is maintained from combustible material and this is indicated by the diagram below. Combustible material other than skirting boards such as joists, floorboards and rafters must be at least 40mm from the chimney masonry or 200mm from the inner surface of the flue.

**Diagram 1 - Chimneys – Separation from combustible materials**

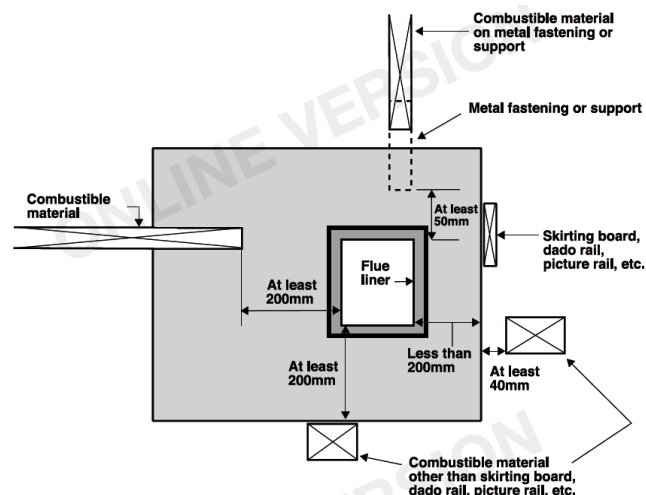

## Single Wall Fluepipes

Single wall enamelled steel pipes are traditionally used to connect the stove to the chimney system. They must be at least three times their diameter from combustible materials. For example a 150mm single skin flue pipe must be at least 450mm from combustible materials (in fact the actual figure is a little higher as this clearance is based on external diameter). The combustible material can be heat shielded in which case the flue must be at least 1.5 times its external diameter away from the heat shield, the heat shield must extend at least 1.5 times the flue's external diameter to each side of the flue, and there has to be an air gap of at least 12mm between the shielding material and the combustible material. Cement based fire protection boards can be used for this purpose.

**Diagram 2 - Single Skin Flue pipes – clearance from combustible materials**

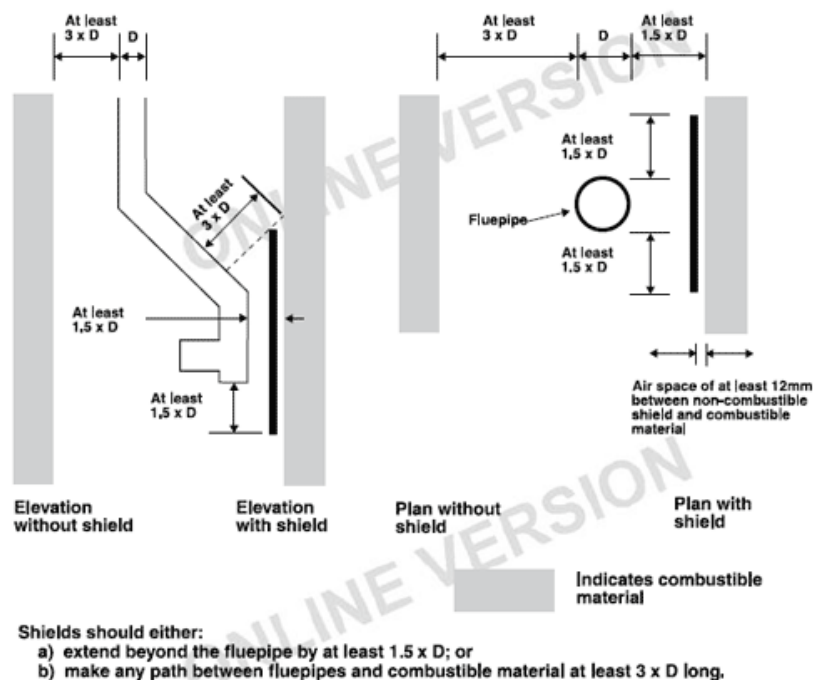

Whilst there is currently no maximum or minimum length specified for a single skin flue pipe that connects a stove to a chimney, it is not permitted to extend beyond the room containing the stove. The length is best kept to a minimum as heat will transfer to the room from the uninsulated flue pipe. This leaves the flue gases colder reducing the 'draw' and allowing a faster accumulation of soot and tar deposits in the chimney.

## Factory Made Metal Chimneys

These systems are used as an alternative to masonry chimneys and consist of interlocking sections with a stainless steel outer casing surrounding high performance insulation and a flue liner made of stainless steel. Some systems have a ceramic or refractory concrete flue liner which offers better resistance to corrosion. Products must meet the requirements of BS EN 1856-1: 2009. The metal lined systems should give a normal life of 10 to 15 years or more when correctly installed, operated and maintained. However, prolonged periods of slow burning particularly using solid fuels, combined with inadequate cleaning of the flue can cause corrosion damage which may reduce the expected life of the liner.

Liners should have a designation of T400 N1 D Vm L40040 Gxx where L40040 is the minimum material specification in the National Annex to BS EN 1856-1 and xx is the necessary separation from combustible materials in millimetres. As for other systems, the manufacturer's installation instructions must be followed exactly ensuring adequate support and provision for expansion. There must be access via inspection hatches at least 300mm square in area to enable

commissioning and maintenance checks to confirm that the flue is continuous, all joints are correctly assembled and gas tight and the flue is adequately supported.

Where passing through a cupboard, room or roof space the metal chimney must be guarded to prevent any combustible material coming to within the xx separation distance mentioned above. Where passing through a floor, manufacturers supply fire stop components to space the chimney from the timber and maintain the fire resistance of the floor. These are usually of the ventilated type however unventilated components are available giving a level of safety from smoke penetration to the room above should a fire occur

### Outlets from Flues and Chimneys

The flue gases from the stove must be able to discharge freely without presenting a fire or health hazard, whatever the wind conditions. To get a good chimney draw the flue outlet needs to be positioned above the zones over the roof surface and around buildings where wind eddies and down drafts can occur

The Approved Document gives comprehensive guidance on how this is achieved. Diagram 3 below illustrates the safe zones for flue outlets in relation to tiled or slated roofs with no factors that may increase wind currents.

**Diagram 3 – Flue Outlet Positions – Normal Roofing Materials and Normal Circumstances**

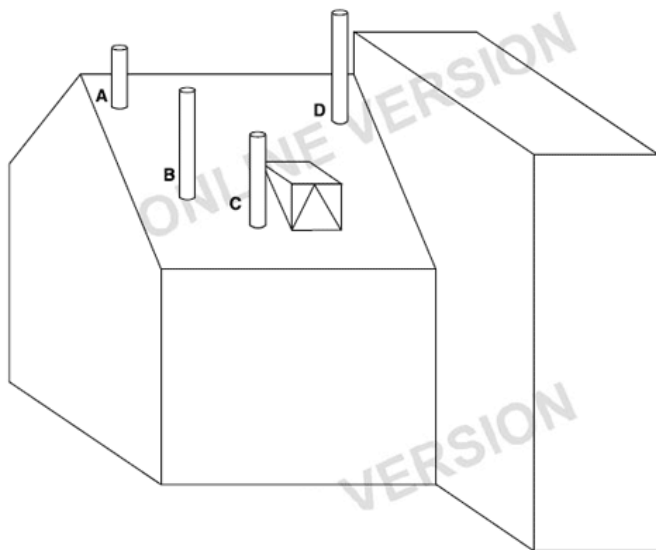

	Point where flue passes through weather surface (Notes 1, 2)	Clearances to flue outlet
<b>A</b>	At or within 600mm of the ridge	At least 600mm above the ridge
<b>B</b>	Elsewhere on a roof (whether pitched or flat)	At least 2300mm horizontally from the nearest point on the weather surface and: a) at least 1000mm above the highest point of intersection of the chimney and the weather surface; or b) at least as high as the ridge
<b>C</b>	Below (on a pitched roof) or within 2300mm horizontally to an openable rooflight, dormer window or other opening (Note 3)	At least 1000mm above the top of the opening
<b>D</b>	Within 2300mm of an adjoining or adjacent building, whether or not beyond the boundary (Note 3)	At least 600mm above the adjacent building
<b>Notes</b> 1) The weather surface is the building external surface, such as its roof, tiles or external walls. 2) A flat roof has a pitch less than 10°. 3) The clearances given for A or B, as appropriate, will also apply.		

- 4) For the purposes of diagram 3 the outlet position is measured to the point of discharge or to 150mm above the insulation whichever is the lower
- 5) For roofs covered with combustible materials like thatch or shingles that are easily ignited the Approved Document gives guidance on the larger clearances that are necessary.
- 6) The dimensions stated may need to be increased to deal with the effects on air currents of higher wind exposure, adjacent tall buildings, high trees or high ground. In other words conformance with the recommendations does not guarantee that the requirements will be met.

### Hearths for Stoves

The purpose of a hearth is to provide a slab of non-combustible material for the stove to stand on that protects any combustible materials underneath and around from the heat of the stove and from any burning fuel that might accidentally fall out of it.

The perimeter of the hearth should be clearly defined – This can be achieved using a raised edge or by raising the level of the hearth in relation to the floor.

Diagram 4 – Hearth

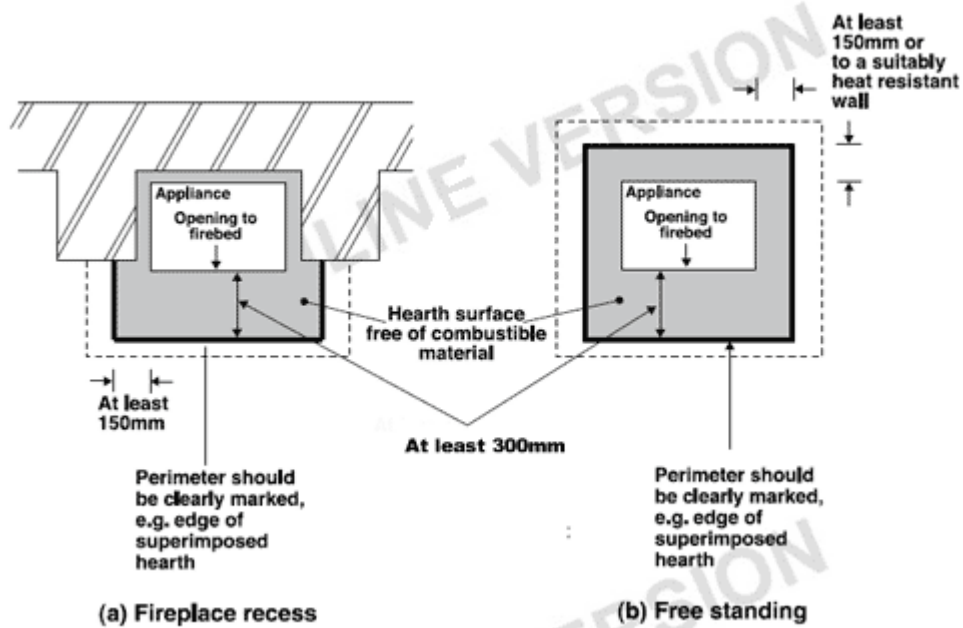

The stove must sit on a hearth extending a minimum of 150mm (6") out from the stove at the sides and 300mm (12") in front. Theoretically the frontal distance can be reduced to 225mm if the stove is not designed to be run with the door open. As most stoves can be run with the door open the 300mm dimension should be used in most cases. The minimum size for a hearth for a freestanding stove (not in a recess) is 840 x 840mm.

Diagram 5 - Hearth thickness

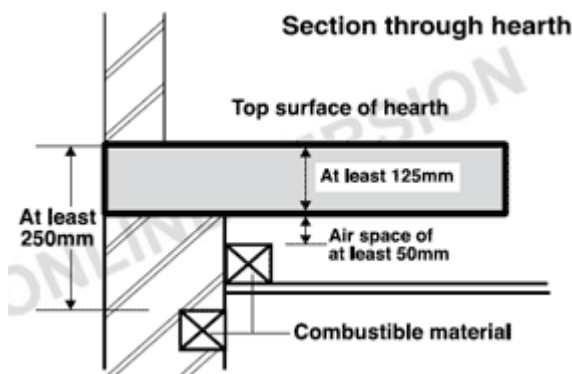

If the hearth is on a combustible floor it must be at least 250mm thick. This is reduced to 125mm if there is a 50mm air gap underneath it (as diagram 5)

If the hearth is on a solid concrete floor slab or pre cast beam and block type floor then the total thickness of the hearth and floor must be 125mm. Combustible insulation should not be placed under this or the total thickness should be increased to 250mm. In all cases above, if a stove has been tested and shown not to raise the hearth temperature to over 100 degrees centigrade then a 12mm hearth may be used.

## Ventilation for stoves

A very important part of installing a stove is ensuring that there is a permanent source of air to enable the combustion process to take place efficiently and safely. Without an air supply stoves are harder to light and can emit smoke into the room. A good chimney draw is reliant on there being a ready supply of air to make up the volume that passes up the chimney with the products of combustion. In extreme circumstances where ventilation is inadequate, incomplete combustion can result in carbon monoxide production due depletion of oxygen. If this highly toxic colourless and odourless gas accumulates in a room it can lead to serious health risks that are potentially fatal. (see CO alarms below)

In recognition of this, Document J lays down stringent standards for providing a permanent combustion air supply to the room containing the stove. These are varied to suit the type of house and the appliance's rated output. Recent building regulations standards for energy efficiency have resulted in buildings becoming more airtight to prevent uncontrolled loss of heat. Such properties need additional ventilation as they can not rely on natural air leakage as can the majority of older properties. Table 1 below shows the ventilation areas needed

**Table 1 - Air Supply for Stoves**

Stove with a draught stabiliser fitted	<p><u>Air permeability &gt; 5.0m<sup>3</sup>/h.m<sup>2</sup></u> 300mm<sup>2</sup> for each kW up to 5kW 850mm<sup>2</sup> for each kW thereafter.</p> <p><u>Air permeability ≤ 5.0m<sup>3</sup>/h.m<sup>2</sup></u> 850mm<sup>2</sup> for each kW</p>
Stove with no draught stabiliser fitted	<p><u>Air permeability &gt; 5.0m<sup>3</sup>/h.m<sup>2</sup></u> 550mm<sup>2</sup> for each kW above 5kW <u>Air permeability ≤ 5.0m<sup>3</sup>/h.m<sup>2</sup></u> 550mm<sup>2</sup> for each kW</p>

A house built before 2006 is unlikely to have an air permeability of less than 5.0m<sup>3</sup>/h.m<sup>2</sup> unless it has had a lot of work done to it (eg double glazing throughout, draught proofing to doors and letterboxes, etc). A house built after 2006 is likely to have had an air permeability test result and your local Building Control office may well have records of the test result.

Some stoves have provisions for drawing outside air directly in through a duct. Otherwise the vent should be placed in such a way that it cannot be easily blocked and so that house residents are not tempted to block it off to reduce draughts or noise. If the vent is close to the stove then draughts are reduced and the room feels warmer. The vent areas in the table relate to 'free area' and not simply the cross sectional area of the air brick or louvered cowl fitted. These products are usually stamped with the free area that they can provide but as a guide a single 215mm x 65mm plastic air brick provides around 6,000mm<sup>2</sup>. Equal sized clay air bricks give as little as 1,300mm<sup>2</sup>. If there is a mesh to guard against pest/mice etc coming through the vent then the mesh size must be no less than 5mm

## Positioning Ventilation for a Stove

The vent can be placed in the walls, ceiling or floor of the room. As illustrated in Diagram 6 it does not have to be in the same room as the stove i.e. ventilation can be provided to another room which itself has permanent ventilation to the outside. A well ventilated roof space or under floor void can provide a convenient source from which to draw a supply of combustion air

Proprietary vents are available (see diagram 7) that can be installed using a 125mm core drill. They incorporate a series of baffles inside the duct to reduce wind noise etc



**Diagram 6 – Vent Positions**

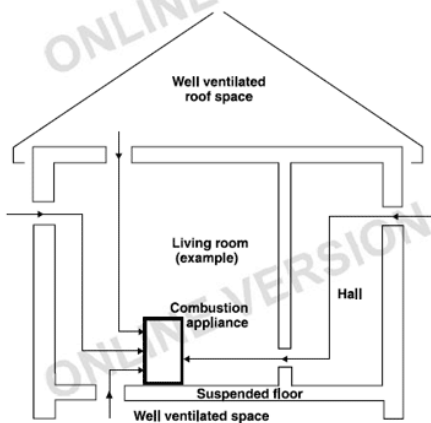

**Diagram 7 – Proprietary Stove Vent System**

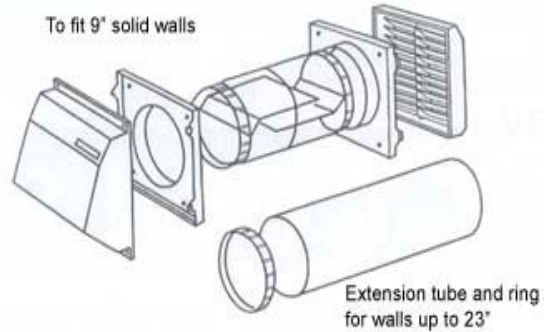

**Notice Plates**

When a new or replacement hearth, flue or chimney is constructed or extended or a flue is re lined, the regulations require that a notice plate is fitted giving information essential to the correct application and use of these facilities. This must permanently posted in the building in a location such as:

- a. by the electricity consumer meter
- b. by the water stop-cock
- c. by the hearth or flue that it describes

The notice plate shows the position of the hearth and/or flue and gives essential information about the materials used such as the manufacturer and flue diameter.

**Diagram 8 – Example notice plate for hearths and flues**

<b>Essential information</b>	<b>IMPORTANT SAFETY INFORMATION</b>	
	<b>This label must not be removed or covered</b>	
	Property address .....	20 Main Street New Town
	The hearth and chimney installed in the .....	lounge
	are suitable for .....	decorative fuel effect gas fire
	Chimney liner .....	double skin stainless steel flexible, 200mm diameter
	Suitable for condensing appliance.....	no
	Installed on .....	date
<b>Optional additional information</b>	Other information (optional) .....	Designation of stainless steel liner stated by manufacturer to be T450 N2 S D 3
	e.g. installer's name; product trade names, installation and maintenance advice, European chimney product designations, warnings on performance limitations of imitation elements e.g. false hearths.	

## **Carbon Monoxide Alarms**

It is now mandatory to install a carbon monoxide alarm complying with BS EN 50291:2001 in rooms containing solid fuel combustion appliances. These devices are usually battery powered and have an alarm to alert users when the working life of the detector is due to pass.

Alarms should be in the same room and within 1 to 3 metres of the appliance and either;-

On the ceiling at least 300mm from any wall or;

On a wall as high up as possible (above doors and windows) but at least 150 mm from the ceiling

Always follow the manufacturers' installation instructions. The provision of an alarm is not a substitute for regular servicing of the stove and flue.

## **Commissioning Checklist**

It is the policy of Building Control Authorities in Hertfordshire to require that installers provide them with a commissioning checklist following the installation of a solid fuel stove and / or a new chimney or chimney lining. The Herts Technical Forum Guidance Note 15 gives information on the associated tests that need to be carried out. It also provides a useful form that can be completed and submitted to Building Control in order to meet this requirement.

## **Planning Permission**

Fitting, altering or replacing an external flue or chimney is normally considered to be permitted development, not requiring planning consent, if the conditions outlined below are met:

- Flues on the rear or side elevation of the building are allowed to a maximum of one metre above the highest part of the roof.
- If the building is listed or in a designated area even if you enjoy permitted development rights it is advisable to check with your local planning authority before a flue is fitted.
- In a designated area the flue should not be fitted on the principal or side elevation that fronts a highway.

The above information relates to houses and not flats or maisonettes. For further information contact the Development Control section at your local council

## **Smoke Control Zones**

Under the Clean Air Act some parts of the country have been designated as smoke control areas. This affects the type of appliance that you can install and the fuel that can be burned in it. For further information contact the Environmental Health section at your local authority.

## **Other Information**

The following websites may be useful in obtaining further information about the installation of solid fuel stoves [www.hetas.co.uk](http://www.hetas.co.uk) [www.planningportal.gov.uk](http://www.planningportal.gov.uk) [www.feta.co.uk/bfcma](http://www.feta.co.uk/bfcma)

You can also contact your local Building Control office at:

