



Building Control

Technical Guidance Leaflet No. 9 *DOWNLIGHTERS IN DWELLINGS*

This leaflet is one of a series produced by the Hertfordshire Building Control Technical Forum

Introduction

The use of downlighters is becoming increasingly common in dwellings and domestic extensions. This has prompted debate on their compliance with associated areas of the Building Regulations.

The purpose of this guidance note is to consider the areas of concern and demonstrate how these luminaires can be specified in order to accord with the various requirements. Subjects covered include fire safety, sound insulation, conservation of fuel and power and compatibility with roofing underlay materials.

Fire Safety

Fire Resistance of Floors

Approved Document B of the Regulations includes requirements that floors in dwellings achieve a fire rating. This is normally 30 minutes for low-rise buildings where the floor is not a compartment floor. When installing downlighters in such a floor, the question arises as to whether or not they will adversely affect its fire resistant properties to the extent that it will not comply.

Whilst there is not a great deal of research information available on this subject, tests sponsored by the DETR (now CLG) and carried out by The Timber Research and Development Association* provided useful guidance. The view of many construction professionals is that additional protection in the form of intumescent covers, boxing or fire resisting fittings is a necessary provision in all cases. It may be that these opinions have been influenced by commercially driven advice from companies dealing in such products. It is important that decisions are based on sound and independent scientific research, it being all too easy to request a higher standard knowing that it is unlikely to be challenged. Building Control Surveyors must be vigilant against being influenced by potentially biased information from the commercial sector. There are some excellent sources of independent advice that they can use to make balanced judgements when checking designs or work on site.

The above TRADA tests were carried out on typical timber joisted floors (measuring 3.2 x 4.2m) fitted with up to 24 plastic and metal clipped fittings of various diameters. All indicated that the unprotected downlighters did not cause premature failure in terms of load bearing capacity, insulation or integrity. It could be argued that such 'laboratory' standards do not represent a floor after the retrospective removal and replacement of areas of floor decking. Such concerns are weakened by the fact that patched areas are inevitably supported on noggins or joists and the tests included decking that was not tongued and grooved. Similar tests were recently carried out by the BRE*** on typical downlighter and sprinkler head penetrations in various timber floor types. These reached similar conclusions to the TRADA research.

Similar tests by TRADA on 60-minute fire resisting floors did not result in premature failure either although this small-scale evidence is insufficient to negate the need for downlighter protection in 60-minute floors. Full-scale evidence may be more onerous so, in the absence of such information, covers should be provided.

It is also important that these tests are not seen as being representative of other floor types such as those incorporating engineered 'I beam' or open steel web joists. Such members have little 'sacrificial' timber so may rely almost entirely on the integrity of the ceiling lining to prevent failure in fire. One manufacturer has sponsored tests** on this type of floor that indicated similar performance to traditional joists and the BRE tests above also included these floor types. These must only be seen as indicative of the fire resistance of floors using identical products and

arrangements to those tested. Protective measures may still be needed in this type of floor unless clearly demonstrated by testing to be unnecessary.

Clearance to Combustible Materials

Due to the high levels of heat generated by this type of fitting, it is essential that a safe clearance be maintained to any combustible or non-combustible materials in accordance with the manufacturer's recommendations. This may preclude the use of downlighters in sloping ceilings where such clearances can not be achieved.

Where the body of a downlighter is exposed within a loft space used for storage, there is a possibility that combustible materials will accidentally be laid over them risking the outbreak of a fire. For this reason, it is good practice to fit clearly visible protective covers as a precaution.

Sound Insulation

Internal floors **within** dwellings

When amended Part E was introduced in July 2003, it brought into effect new controls on the sound insulating properties of floor construction within dwellings in addition to revising the existing requirements concerning separating floors. This has caused surveyors to consider the impact of downlighter installation in such floors and whether the 40 R w dB sound insulation value would still be achievable. Acoustically rated fittings are available but are they necessary?

The advice from experienced acoustic consultants is that their effect on sound insulation properties is relatively negligible. Previous tests would suggest a reduction of only 1 – 2 dB. In view of the popularity of such fittings it would seem reasonable to incorporate them in internal floors without any additional measures.

Separating floors **between** dwellings

The use of downlighters in various separating floor constructions is covered in the Robust Details Guide. This states that there should be a minimum ceiling void of 75mm and that: - they should be fitted in accordance with manufacturers recommendations,

- a) At no more than one light per 2m² of ceiling area in each room
- b) At centres at not less than 750mm, and
- c) Openings in the lining should not exceed 100mm diameter or 100 x 100mm if square.
- d) Only downlighters that have been assessed in accordance with the procedure described in the robust details guide Appendix F are acceptable. Developers who opt to register in accordance with a robust detail should not deviate from this associated guidance. For separating floors not covered by robust details it would seem sensible to advise against their use. There is little relevant commentary in the Approved Document and such penetrations may be the cause of failure in the necessary pre-completion testing.

Thermal Insulation

Cold bridging

A common sight in newly built extensions and dwellings is a roof space insulated with 270mm thick mineral wool quilt with countless uninsulated patches around the downlighter fittings in the ceilings. The cumulative effect of this in terms of heat loss can be substantial.

Under the procedure for calculating U-values of elements in BR443 2006 (conventions for U-Value Calculations) there is provision for taking such uninsulated areas into consideration to give an area weighted average U-value for a roof or floor. In other words an increase in the insulation thickness elsewhere may compensate for the gap around the fitting which should be no more than is required as clearance by the manufacturer. Such calculations are not often available in connection with smaller projects so other measures are appropriate to demonstrate compliance. The boxing in detail shown below is accepted by most Local Authorities

Downlighter bulbs are available that mainly direct heat downwards. This results in far less heat production above the unit and allows a small pocket in the insulation to safely accommodate the fitting. Unfortunately there is a basic flaw in relying on this arrangement as the bulbs are interchangeable and in replacing with a standard bulb, an owner could inadvertently cause a build up of heat under the insulation layer.

There are also new light emitting diode (LED) models now coming onto the market that have the advantage of creating very little heat (see 'efficient lighting' below) making it possible to cover the fittings with insulation and eliminate cold bridging entirely. Many LED fittings do run hot so careful selection is essential.

Air Leakage

The energy efficiency of a new dwelling or extension is partly reliant on the quality of the construction to minimise the loss of heat due to uncontrolled air leakage. Most new dwellings now undergo air leakage testing on completion so careful specification of downlighters is important. Those that penetrate the ceiling to an insulated roof must be specified and installed to maintain a reasonably airtight seal. This may be by using an integrally sealed unit or by fitting a hood or boxing over the fitting as shown below (see also section on vapour permeable underlays)

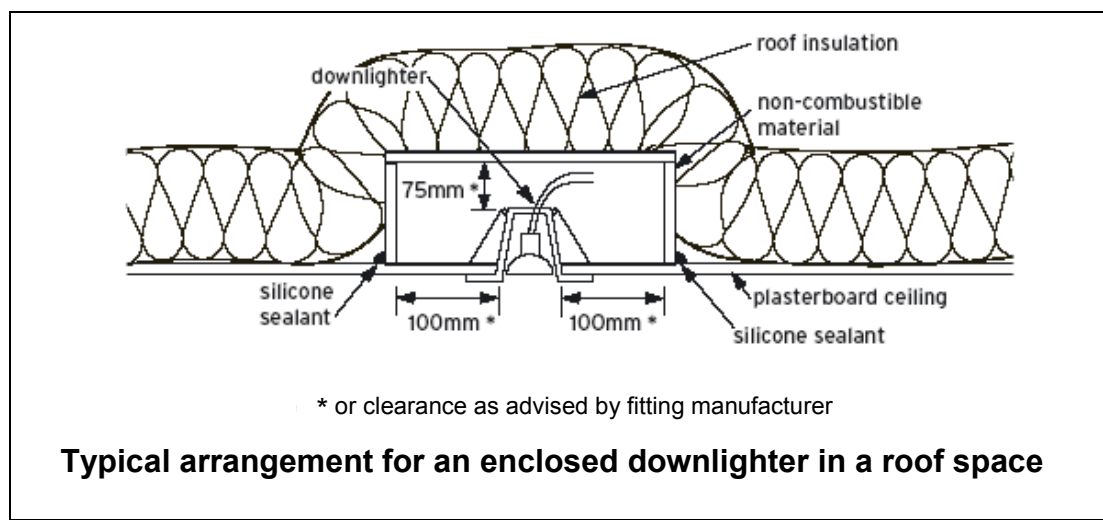

Efficient Lighting

Approved Documents L.1A and L.1B also give guidance on the minimum provision of energy efficient lighting. They advise that at least 3 out of four light fittings should be low energy type i.e. have luminous efficacy of not less than 45 lumens per circuit-watt and total output greater than 400 lamp lumens. Light fittings supplied by less than 5 watts can be excluded from the overall count. Standard fittings with low energy lamps are acceptable.

Compatibility With Roof Underlay Materials

The introduction of high performance 'vapour permeable' roofing underlays created a potential for designers to reduce or omit altogether the usual provisions for cross ventilation as a precaution against the build up of interstitial condensation in the roof void. In order to comply with the Regulations when using this type of underlay, the design and installation must accord with BS: 5250:2002 or with accredited installation details in BRE and BBA certificates for the underlay products. This means that the ceiling to the roof must be 'well sealed' to minimise the passage of water vapour to the roof space. The use of standard open downlighters is not compatible with this aim so the designer may decide to specify fittings that are suitably sealed against the passage of vapour. Alternatively they should incorporate an appropriate sealed box or hood such as the type detailed above. Standard 'fire hoods' are not necessarily suitable for this purpose.

In Conclusion

We hope that the above information will enable the reader to confidently specify the use of downlighters without conflicting with any of the relevant sections of the Building Regulations. You are welcome to contact your Local Authority Building Control Office for further information on this subject.

- * **Trada Technology Report 1/2001**
Timber frame walls and floors: Fire resistance of service penetrations ISBN 900510 28 6
www.trada.co.uk

- ** **Chiltern International fire assessment FEA/F97099 RevC**
TJM Europe TJI/PRO 150,250,350 and 550 series Floor Joist System
www.chilternfire.co.uk

- *** **BRE Communities and Local Government**
Final Research Report: BD 2551 2007
Residential sprinkler installation practice to maximize functionality and to prevent possible fire penetration
www.bre.co.uk